

# SBTL-LG Mount

## Weighing Mount

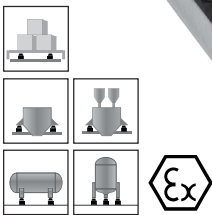
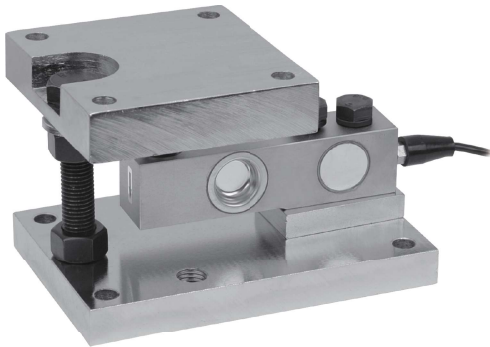
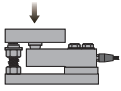

### Capacities

0.5t, 1t, 2t

### Features

- Alloy steel construction / stainless steel construction (option)
- Mounts to floor or structural support directly
- SBTL (single ended shear beam load cell) installed
- Support bolt to avoid overturn
- Protected against corrosion by nickel-plated treatment
- Suitable for floor scales, blending & mixing systems and batching systems, etc.

### Schematic

- Red : + input
- Black : - input
- White : - output
- Green : + output

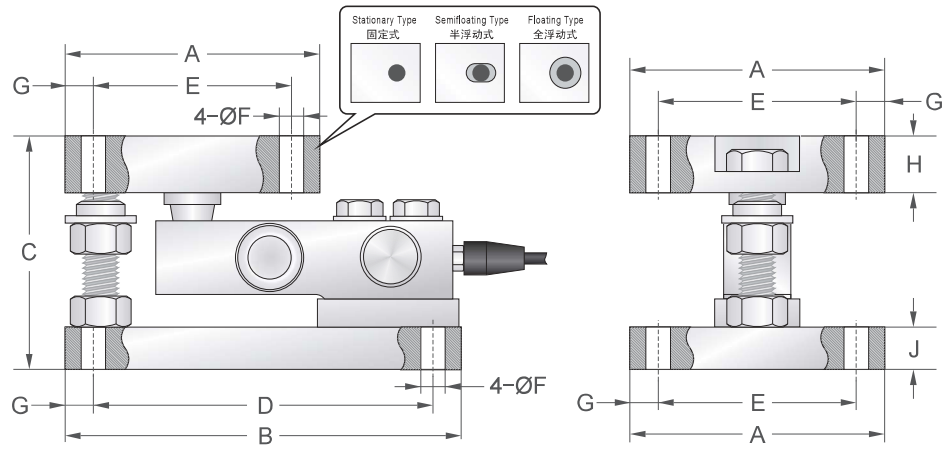
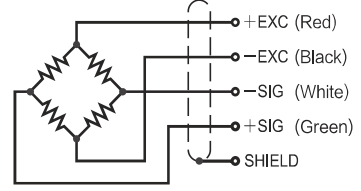

Capacities		A	B	C	D	E	F	G	H	J
0.5t~2t	mm	114.3	177.8	104.7	152.4	88.9	11	12.7	25.4	19

### Installation

