

SBT-FW Mount

Weighing Mount

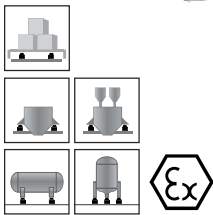
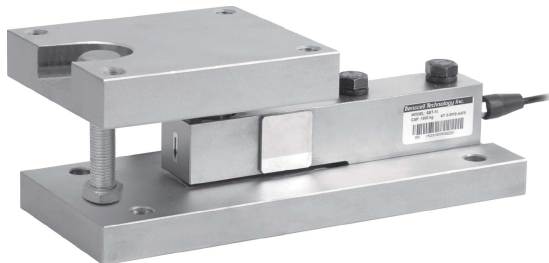
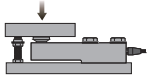

Capacities

SBT - 500kg, 1000kg, 2000kg, 3000kg, 5000kg

SB - 10000kg, 15000kg, 20000kg

Features

- Alloy steel construction
- Support bolt to avoid overturn throughout
- Mounts to floor or structural support directly
- SBT/SBT (single ended shear beam load cell) installed
- Support bolt to avoid overturn throughout
- Protected against corrosion by nickel-plated treatment
- Suitable for floor scales, blending & mixing systems and batching systems, etc.

Schematic

- Red : + input
- Black : - input
- White : - output
- Green : + output

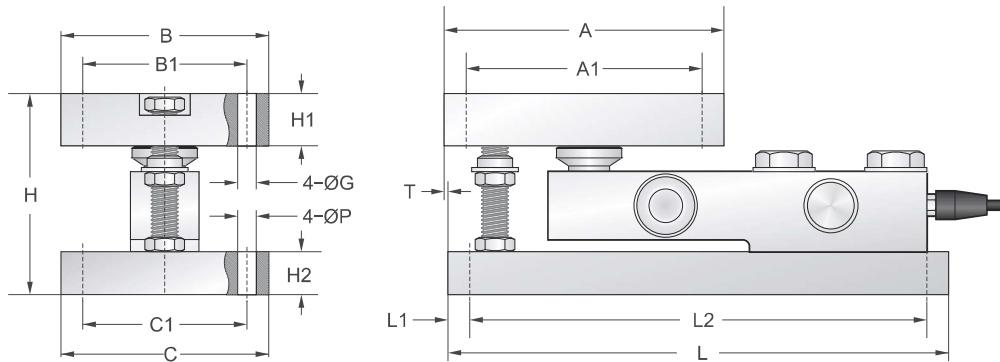
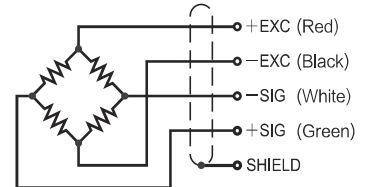

Capacities		L	L1	L2	A	A1	B	B1	C	C1	H	H1	H2	G	P	T
0,5t-3t	mm	286	32	226	150	124	128	102	112	80	102	28	23	11	13	3
5t	mm	317.5	32	257	178	146	152	120	152	102	130	38	30	17.5	17	0
10t	mm	360	32	295	184	152	154	122	154	106	168	45	45	22	21	0
15t/20t	mm	400	25	350	220	170	220	170	220	170	213	55	55	26	26	0

Installation

